

**PLAN VIEW**

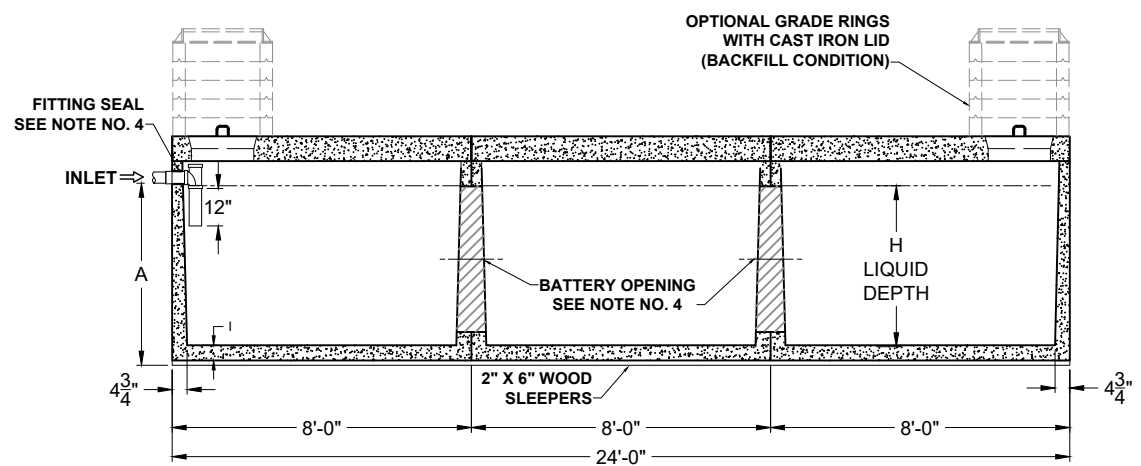

**SECTION THRU "A-A"**

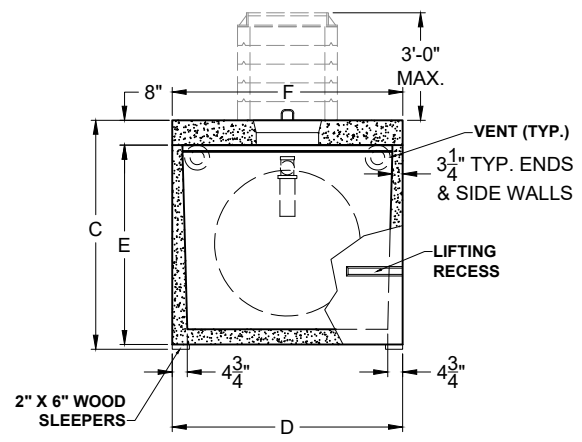

**SECTION THRU "B-B"**

*H-20 TRAFFIC RATED  
"HEAVY DUTY"*

ALL DIMENSIONS ARE IN INCHES & WEIGHTS IN LBS - (RISER WT. NOT INCLUDED)										EXCAVATION SPECIFICATIONS				
MODEL	A	B	C	D	E	F	G	H	I	WEIGHT	LENGTH	WIDTH	BELOW INLET	TANK HEIGHT
PC H-3-3750-HD	59	N/A	74	74	64	74	29 1/4	50 1/2	4 1/2	41,625	27'-0"	9'-2"	4'-11"	6'-2"
PC H-3-4500-HD	62 1/2	N/A	77 1/2	85	67 1/2	85	30 3/4	53 1/2	5	48,660	27'-0"	10'-1"	5'-2 1/2"	6'-5 1/2"

**PRODUCT NAME:**  
**HOLDING TANK**

**DESCRIPTION:**  
3750 THRU 4500 GALLONS  
H-20 TRAFFIC RATED

**DESIGN SPECIFICATIONS**  
**DESIGN LOAD: H-20 TRAFFIC RATED**

WITH DRY SOIL CONDITIONS (WATER LEVEL BELOW TANK). SUITABLE SUB-BASE BEDDED WITH GRANULAR MATERIAL SHALL BE PREPARED TO HANDLE ANTICIPATED LOADS. FOR COMPLETE DESIGN AND PRODUCT INFORMATION, PLEASE CONTACT PRO-CAST PRODUCTS.

PRO-CAST PRODUCTS RESERVES THE RIGHT TO MAKE CHANGES TO PRODUCT DESIGN AND/OR DIMENSIONS WITHOUT NOTICE. PLEASE CONTACT PRO-CAST PRODUCTS WHENEVER NECESSARY FOR CONFIRMATION OR ADVICE ON PRODUCT DESIGN.

- NOTES:**
1. NOT USED
  2. REFER TO SPECIFICATION SHEET NOS. S-251 & S-252
  3. REFER TO SPECIFICATION SHEET NO. S-201
  4. REFER TO SPECIFICATION SHEET NO. S-250

**SCALE:** DO NOT SCALE  
**DRAWN BY:** TPC 12.20.2024

**REVISED BY:**  
**CHECKED BY:**

**DRAWING NO.**  
**H-004**